

S-L Seatiger

(The original and genuine S-L 555 Windlass)

**DOUBLE ACTION
TWO SPEED
LEVER WINDLASS**



CONTENTS

1. PARTS

- 1.1 Exploded Diagram
- 1.2 For Future Reference
- 1.3 Parts List

2. SPECIFICATION

- 2.1 Suitability
- 2.2 Performance
- 2.3 Materials
- 2.4 Package Contents

3. ACCESSORY

4. PLANNING THE INSTALLATION

- 4.1 Additional Requirements

5. INSTALLATION

- 5.1 Fitting Windlass to Deck
- 5.2 Joining Rope to Chain

6. OPERATING INSTRUCTIONS

- 6.1 Safety First!
- 6.2 Veering (Letting go)
- 6.3 Lying to Anchor Safely
- 6.4 Hauling In
- 6.5 Warping
- 6.6 Operating Tips

7. IMPORTANT USER INFORMATION

8. MAINTENANCE

- 8.1 General Recommendations
- 8.2 Winter Laying Up

9. RETROFIT KITS

10. WARRANTY



SIMPSON

I. PARTS

I.1 Exploded Diagram

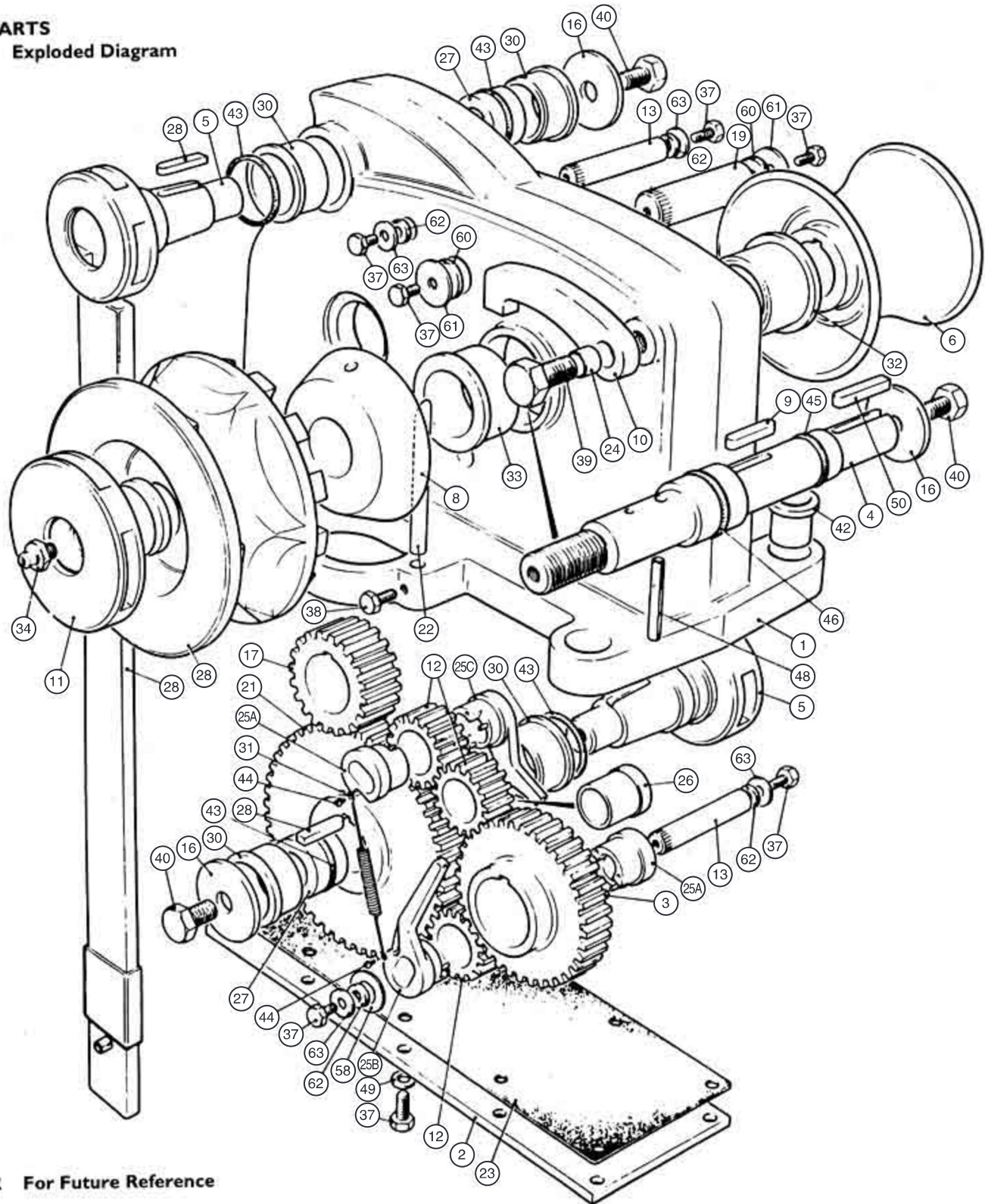

I.2 For Future Reference

After you have read this instruction booklet, please keep it safe on board your vessel for future reference.

I.2.1 Identify your model

Model	Gipsy Type	List No.	Gipsy	Drum	Tick
High Spec	Rope/Chain	0055595	Bronze Chrome Plated	Bronze Chrome Plated	
Stand -ard	Rope/Chain	0055590	Bronze	Aluminium Anodised	
Stand -ard	Chain Only	0055500	Cast Iron Galvanised	Aluminium Anodised	

I.2.2 Please note your serial number, which can be found stamped on the upper surface of the base flange near the chain pipe.

The above information is essential when ordering spares.

1.3 Parts List

Ref. No.	Description	Quantity	List No.
1	Case	1	
2	Bottom Cover	1	
3	Mainshaft Gear	1	
4	Mainshaft	1	
5	Operating Spindle	2	
6	Drum	1	
7	Gipsy	1	
8	Clutch Cone	1	
9	Key	1	
10	Locking Pawl	1	
11	Clutch Nut	1	
12	Idler	3	
13	Ratchet Shaft	2	
16	Operating Spindle Washer	3	
17	Low Speed Gear	1	
19	Idler Shaft	1	
20	Operating Handle	1	6055520
21	High Speed Gear	1	
22	Rope Chain Stripper	1	
23	Bottom Gasket	1	6055523
24	Pawl Bolt Tube	1	
25A	Ratchet Bush	2	
25B	Ratchet Bush with Arm	1	6055593
25C	Ratchet Bush with Short Arm	1	
26	Idler Bush	1	
27	Bush	2	
28	Key	2	
30	Operating Spindle Bush	4	
31	Spring	2	
32	Mainshaft Bush, Port	1	
33	Mainshaft Bush, Starboard	1	
34	Grease Nipple	1	6055534
37	Screw	16	
38	Screw	1	
39	Screw	1	
40	Screw	3	
44	Screw	4	
42	Headed Bush	4	6055542
43	O Ring	4	
45	O Ring	1	6055595
46	O Ring	1	
48	Spring Pin	1	
49	Washer	10	
50	Key	1	
58	Ratchet Bush Spacer	2	
60	Idler Shaft Seal	2	
61	Idler Shaft Washer	2	
62	Ratchet Shaft Seal	4	
63	Ratchet Shaft Washer	4	
	Grease	1	6055592

2.1.2 Anchor Cable Suitability

The patented rope/chain gipsy enables the windlass to be used for hauling rope and chain without the need to transfer from warping drum to gipsy. It is ideally suited to anchor rodes which consist of rope runs with a tail scope of chain.

Rope used with rope/chain gipsies should be 16 mm (5/8") diameter three strand nylon.

The grip of the gipsy on the rope depends on the lead angle of the rope to the gipsy. The internal angle of the rope, formed when it wraps round the gipsy, should never be greater than 90°. It may also be necessary to tail the rope taught to give satisfactory performance.

GIPSY	ROPE / CHAIN	
RCB60	S-L 0058006 / 0058206	1/2"
	American BBB	7/16"
	American BBB	1/2"
	American Proof Coil	3/8"
	American Proof Coil	7/16"
	American Hi Test	7/16"
RCB70	S-L 0058004 / 0058202	9.5 mm
	American BBB	3/8"
	American Hi Test	3/8"
	Most European	10 mm
GIPSY	CHAIN ONLY	
B80	S-L 0058003 / 0058203	5/16"
	American BBB	5/16"
	American Hi Test	5/16"
	Most European	8 mm
B74	S-L 0058004 / 0058204	9.5 mm
	S-L 0058005 / 0058205	7/16"
	American BBB	3/8"
	American Proof Coil	5/16"
B65	S-L 0058006 / 0058206	1/2"
	American BBB	7/16"
	American BBB	1/2"
	American Proof Coil	3/8"
	American Hi Test	3/8"
BB54	American Proof Coil	1/2"
	American Hi Test	1/2"

Depending on manufacture, other chains in the range 8mm (5/16") to 12mm (1/2") with a pitch up to 36mm (1. 3/8) may be suitable with one of the above gipsies. Should difficulty be experienced in fitting a chain please consult your local agent or Simpson-Lawrence Limited.

2.2 Performance

Typical Working Figures

Input Load	Output	
	High Speed	Low Speed
15 kg	175 kg	500 kg
33 lb	385 lb	1100 lb

2. SPECIFICATION

2.1 Suitability

2.1.1 Suitable for vessels up to 17m (56ft) LOA

2.3 Materials

Shaft	303 Stainless Steel
Gears	Machine Cut Steel
Case	Aluminium BS 1490 LM6
Weight	18 kg (40 lb)

2.4 Package Contents

Windlass
Windlass Operating Handle
Four Headed Mounting Bushes
Instruction Booklet

3. ACCESSORY

List Number	Item
0055505	Windlass Cover

4. PLANNING THE INSTALLATION

4.1 Additional Requirements

Each windlass installation requires :

- The following tools:
 - 14mm (9/16") Diameter Drill
 - Jig Saw or Trepanning Tool
 - 19mm Spanner
- Four 12mm (1/2") Diameter Mounting Bolts, Nuts & Washers. (Preferably of stainless steel but heavy duty galvanised bolts are suitable.)
- Sealant

5. INSTALLATION

5.1 Fitting Windlass to Deck

- 5.1.1 If the deck top is not flat a suitable mounting pad may be required to take up camber or sheer. Decks which are thin, or of foam or balsa laminate construction, will require a backing piece in order to spread the loads which will be applied locally to the deck while the windlass is in use.
- 5.1.2 Cable lead from the bow roller should be in the same plane as the centre of the gipsy so the windlass may require to be angled relative to vessel's centre line or positioned to one side of it. Ideally, the chain should lead forwards and downwards from the gipsy to the stemhead roller to ensure the best operation of the gipsy.
- 5.1.3 Place the windlass on the deck or mounting pad in the desired position and check the line up of the chain or rope with reference to the stemhead roller and the chain locker below. Check that there is sufficient room to operate the winch handle without obstruction.
- 5.1.4 When a location has been decided upon, mark the position of the mounting bolt hole centres and the chain pipe hole.
- 5.1.5 Remove the windlass from the deck and bore four 14mm (9/16") holes for the mounting bolts and cut out the outline of the chain pipe hole.
- 5.1.6 Turn the windlass over and apply a suitable sealant around the perimeter of the base and around the bolt holes.
NB If using silicone or other rubbery type sealants it is advisable to allow curing of the sealant before final tightening of the mounting bolts.
- 5.1.7 Turn the windlass back over and insert the nylon bushes in the 'feet'. Place the windlass in position and bolt it to the deck.

5.2 Joining Rope to Chain

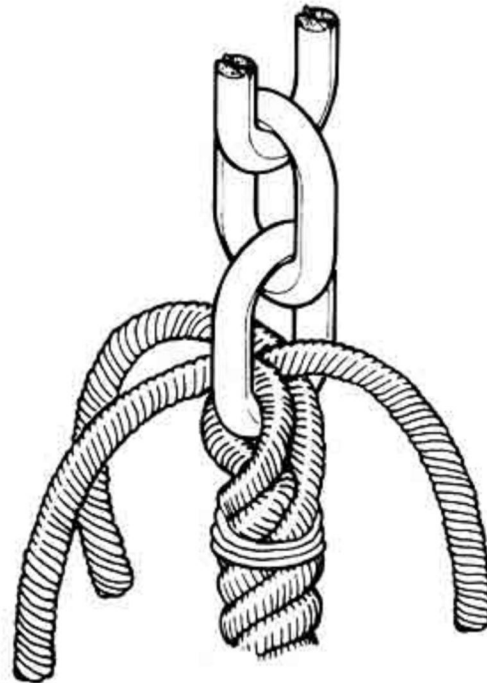

- 5.2.1 With whipping twine or similar, seize your rope 300 mm (12") from the rope's end and unlay the strands.
- 5.2.2 Pass one strand through the chain end link from one side and the other two strands from the opposite side.
- 5.2.3 Remove seizing and complete back splice in normal manner for two full tucks.
- 5.2.4 With a hot knife pare down the three strands by one third and continue with two further tucks.
- 5.2.5 Pare strands down by another third and finish with another two tucks.
- 5.2.6 Cut away remaining tails.

This method of joining is designed to minimise chafe between rope and chain but as a matter of prudent seamanship it should be checked regularly and remade if there is any evidence of wear.

The rope chain gipsy is not a self tailing device, therefore rope, of the correct size, will require to be tailed sufficiently taut to allow it to grip in the rope channel. Because of wide variations in rope type and construction some experimentation may be required.

6. OPERATING INSTRUCTIONS

6.1 Safety First

Ensure that fingers and items of loose clothing are kept clear of the chain and gipsy whilst they are in motion to avoid personal injury! Always make sure that there are no swimmers liable to be injured before lowering your anchor.

6.2 Veering (Letting Go)

- 6.2.1 Disengage the gipsy pawl (10).
- 6.2.2 Insert the operating handle in the clutch nut (11).

- 6.2.3 Release the cable by pulling the handle aft.
- 6.2.4 As the cable runs out its speed can be controlled by gently moving the handle to and fro.
- 6.2.5 When the desired length of cable has been run out, re-tighten the clutch nut and engage the gipsy pawl.

6.3 Lying to Anchor Safely

- 6.3.1 Boats lying to their anchor in a high swell or heavy weather conditions will snub on the anchor or mooring rope and this can cause the chain to slip or apply excessive loads to the windlass.
- 6.3.2 For maximum safety the windlass must not be left to take the entire force from the anchor cable and a bridle should be used to transfer the load to a mooring cleat or bollard. Alternatively, the chain can be removed from the windlass gipsy and made fast directly to a bollard or sampson post.

6.4 Hauling In

- 6.4.1 There are two operating speeds, high speed on the port side and low speed on the starboard.
- 6.4.2 Insert the operating handle in the port operating spindle and move it back and forth.
- 6.4.3 If the effort required becomes excessive change the handle over to the starboard operating spindle.
- 6.4.4 Always choose the speed to minimise the effort.

6.5 Warping

- 6.5.1 If the gipsy is in use, ensure that the gipsy pawl is engaged.
- 6.5.2 Slacken the clutch nut to disengage the gipsy clutch.
- 6.5.3 The warping drum can now be made to revolve independently of the gipsy when the input power is applied.
- 6.5.4 Rope / drum slippage can normally be overcome by increasing the number of turns of rope taken on the drum.

6.6 Operating Tips

- 6.6.1 When anchoring it is best to allow the chain to run out slowly, allowing the vessel to take up sternway before full scope is let out. This helps prevent the chain from becoming tangled on top of your anchor on the sea bed.
- 6.6.2 To aid anchor recovery under conditions where wind or tide cause additional load on the anchor, we recommend that the vessel's engine be used to assist by lessening the load on the windlass and by providing the opportunity for greater control when the anchor breaks out.
- 6.6.3 When mooring stern to, drop the anchor at the required distance from the jetty and gently ease off the gipsy clutch just enough to allow the chain to run out under the influence of the stern way of the vessel, preventing the bows from swinging.
By engaging the clutch fully, the anchor can be used to restrain the vessel as it approaches the jetty. Make fast your vessel with warps from the stern.

7. IMPORTANT USER INFORMATION

Classification Societies require that a vessel lying to anchor should have its chain held by a cable stopper or equivalent strong point as windlasses are not designed to withstand the loads generated under storm conditions.

This rule should be applied to all craft!

Whilst under way it is the responsibility of the boat user to ensure that the anchor and rode are properly stowed for the prevailing sea conditions. This is particularly important with high speed power boats.

An anchor windlass is mounted in the most exposed position on a vessel and is thus subject to severe atmospheric attack resulting in a possibility of corrosion in excess of that experienced with most other items of deck equipment.

As the windlass may only be used infrequently, the risk of corrosion is further increased. When the windlass is mounted in an anchor well with a closing lid, due to lack of ventilation and consequent high saline conditions the rate of corrosion is accelerated.

It is essential that the windlass is regularly examined, operated and given any necessary maintenance. This is of even greater importance when the windlass is installed in an anchor well!

8. MAINTENANCE

8.1 General Recommendations

- 8.1.1 After the first two or three anchor recoveries, check that the windlass is still fastened tightly to your deck as it should now be 'bedded-in'.
- 8.1.2 Regularly wash down the exterior of your windlass with fresh water.
- 8.1.3 Regularly lubricate the nipple on the mainshaft with Shell Alvania or similar grease.
- 8.1.4 Occasionally apply a few drops of oil to the operating spindles and the mainshaft where they enter the main case.
- 8.1.5 The geartrain has been lubricated for you with Shell Mytilus 'A' grease and should require no regular attention, except that as with all types of similar equipment it is advisable to operate the windlass occasionally to circulate the lubricant.
- 8.1.6 For smoothest operation of the clutch ensure that the clutch cones and their seats on the sides of the gipsy are kept free from excess salt deposits.

8.2 Winter Laying Up

Given correct installation and maintenance your windlass will require little attention prior to, or after, winter lay up. The gipsy can be removed from the mainshaft when laying up and grease smeared onto its bore, the gipsy cone and the mainshaft. Check between the windlass deck housing and deck for signs of water ingress. Should it occur, remove, clean and reseal the deck plate.

9. RETROFIT KITS

This booklet refers to windlasses manufactured after May 1982, from serial number 582001. Windlasses prior to this number can be retrofitted to bring their mechanism into line with present production.

Retrofit Kit 'B' List No. 6055591 Replaces ratchet shaft (13) and idler shaft (19)

Retrofit Kit 'C' List No. 6055592 Grease replacement. If this is used it is necessary to use Kit D

Retrofit Kit 'D' List No. 6055593 Replaces ratchet bushes (25) to improve ratchet action.

10. WARRANTY

The Simpson-Lawrence warranty covers your unit for a period of one year from the date of purchase, to be free from defects in material and workmanship. This warranty is subject to proper installation and use in service as described in this booklet.

The models described in this document are subject to a policy of continual improvement. Simpson-Lawrence Ltd reserve the right to alter specifications and recommendations without notice. For the latest information regarding any aspect of your windlass please contact your local agent or:-

Simpson-Lawrence Limited,	218/228 Edmiston Drive, Glasgow, G51 2YT, United Kingdom.
Telephone No. Domestic:	041-427-5331/8
International:	Code+44-41-427-5331/8
Fax No. Domestic:	041-427-5419
International:	Code+44-41-427-5419
Telex No. :	778312 AFLOAT G

Jay Stuart-Haft Co. Inc.,	PO Box 11210, Brandenton, Florida, 34282-1210, United States of America.
Telephone # Domestic:	813-746-7161
International:	Code+1-813-746-7161
Fax # Domestic:	813-746-7166
International:	Code+1-813-746-7166
Telex # :	0230808778

